

Resistor Networks

(Physics 7, Experiment #3)

Purpose:

To study voltage and current relationships in resistors networks.

Apparatus:

- Multimeter with leads
- Power Supply
- Bread Board
- 3 Resistors, 10k Ω , 1k Ω , and 2.2k Ω
- Connecting wires

Procedure

Part 1: Reading Resistor Color Codes

Look at the supplied resistors, notice they each have color bands on them which indicate the nominal value of the resistance. To read the resistance value, hold the resistor so that the gold or silver band is at the right.

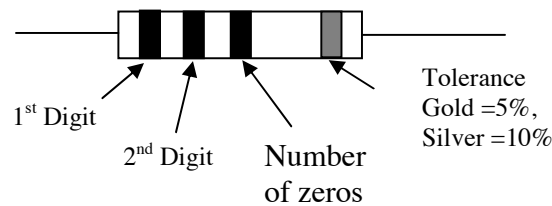

Colour	Value
Black	0
Brown	1
Red	2
Orange	3
Yellow	4
Green	5
Blue	6
Violet	7
Grey	8
White	9

The first color band gives the first digit, the second color band gives the second digit, and the third is the multiplier (or the number of trailing zeros). For instance: if the colors are Orange, Orange, Red, the value is 3300, or 3.3K. The gold or silver band is the tolerance band that indicates how precise the resistor value is.

A gold band indicates that the actual value is within 5% of the nominal value. A silver band indicates that the tolerance is 10%.

You will practice reading the color codes by first determining the nominal values using the color codes and then actually measuring the resistance using the multimeter.

To use the multimeter to measure resistance switch it to the Ω setting. If your multimeter is not autoranging, switch it to the 20k Ω range. On this setting the resistance will be displayed in k Ω . Plug the black probe into the COM connection, and the red probe into the V Ω connection.

Place one of the resistors in the breadboard as shown to make it more convenient to apply the probes. Make sure that the resistor is isolated and will not be connected to any other components on the board. Touch both leads of the resistor with the probes simultaneously and note the reading. The polarity of the probes does not affect the result, in other words if the red and black probes are swapped, the reading will be the same. Record your results on the datasheet and repeat your measurement for each resistor.



Fig 1: Probe connections for measuring voltage and resistance

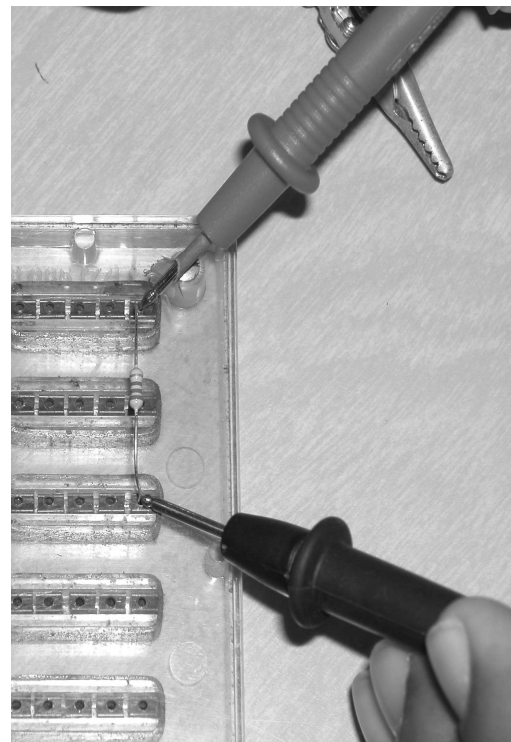

Fig 2: Using the probes to measure resistance.

Part II: Combining Resistors

Using the breadboard to make connections between components, create the following circuit. Your circuit might look like the image on the right. Ensure that the lead of the resistor is in contact with the copper clip in the bread board.

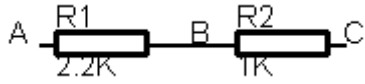

Fig 3. Schematic of Two Resistors in Series



Fig 4: Two resistors in series on a breadboard

Measure the resistance between points A & C. Use the resistor combination rules to calculate the predicted answer and compare with your measured value

Now create a circuit consisting of two resistors in parallel as shown in Fig. 5. Measure the resistance between points A and B and record your results on the datasheet.

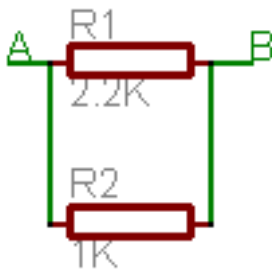

Fig 5. Schematic of Two Resistors in Parallel

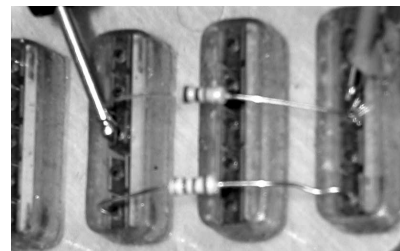

Fig 6. Two resistors in parallel on a breadboard

Part III: Current and Voltage in Series Circuits

Switch the power supply to the 3V setting. The actual voltage will be slightly different from this value. Create the following circuit on the breadboard and apply power to points A and D.

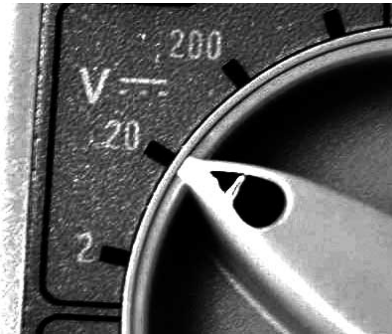
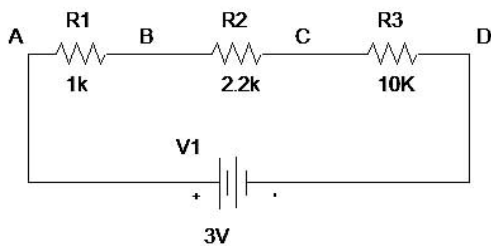

Fig 7. Schematic of Three Resistors in Series

Fig 8. DC Volts setting on a multimeter without autoranging

Turn the dial on your multimeter to the Volts DC setting as shown in Fig. 8. If your multimeter is not autoranging, use the 20V setting. The probes need to be plugged into the multimeter as shown in Fig 1. Measure the Voltages between points AD, AB, BC, and CD. If the readings are negative, repeat the measurement with the red and black leads reversed. Apply ohms law to determine the current in each resistor. Record your results on the datasheet.

With the multimeter on the voltmeter setting, the resistance of the meter is very high and hence draws little current. Hence it is very difficult to damage a circuit by probing voltages. In the next step, the current in the circuit will be directly measured. When the multimeter is set to measure current the resistance of the meter is very low, hence damage to a circuit can occur unless one is very careful. The meter is usually fused to prevent excessive current flowing but the fuse protection may not be sufficient to prevent damage to sensitive circuits. To measure current the circuit must be broken at some point and the meter inserted so that the circuit current will flow through the meter allowing it to be measured. To measure small current of less than 200mA the probes must be plugged in as shown in Fig.9 and the knob must be set to DC Amps as shown.

Break the circuit at point B by reconfiguring the components on the breadboard. An example of how to do this is shown in Fig. 10. Press the probe ends against the loose ends of the broken circuit. A current will begin to flow in the circuit you may have to adjust the range to obtain a result with acceptable precision. Record your result on the datasheet.



Fig 9: Probe connections for measuring small currents.

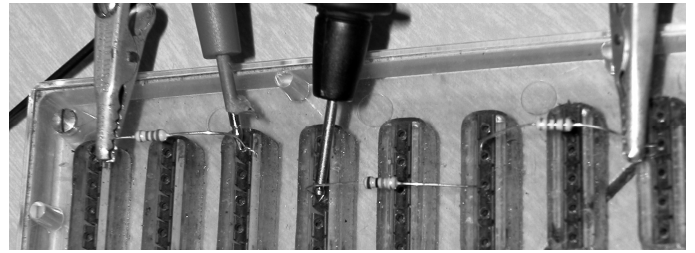

Fig 10: Breaking the circuit so that an ammeter may be inserted into it..

Part IV: Current and Voltage in Parallel Circuits

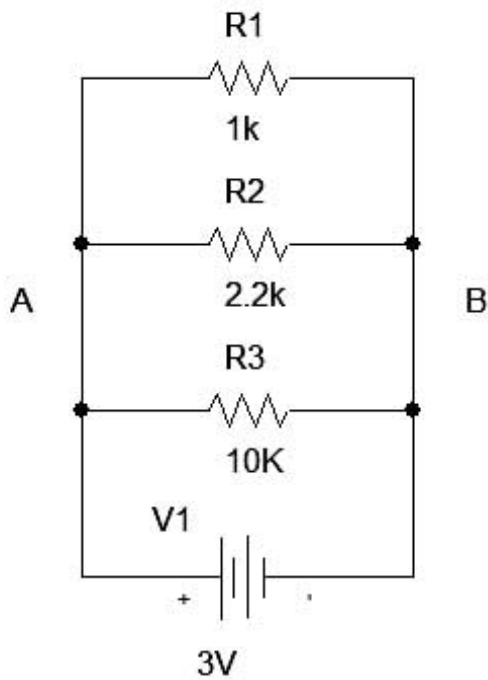

Fig 11: Three resistors in parallel

Construct the circuit shown in Fig 11. Measure the voltage across each resistor (don't forget to connect the probes to the correct multimeter inputs) and use Ohm's law to determine the current in each resistor. Record your results on the datasheet.

Directly measure the current in each branch of the circuit.

Datasheet

1. Reading Resistor Color Codes

1st Band Color	2nd Band Color	Multiplier Band Color	Nominal Resistance (k Ω)	Measured Resistance (k Ω)	Difference (k Ω)	%(Difference/Nominal)

2. Resistors in Series and Parallel

Actual Values		Measured Value for R1 and R2 in series	Predicted Value	% Error
R1	R2			

Show working for predicted value for resistors in series here:

Actual Values		Measured Value for R1 and R2 in parallel	Predicted Value	% Error
R1	R2			

Show working for predicted value for resistors in parallel here:

3. Voltages and Currents in a Series Circuit

Points	Voltage (V)	Measured Equivalent Resistance between Points (Ω) (using values from step 1)	Predicted Current Through Branch using Ohm's Law (mA)
AD			
AB			
BC			
CD			

Direct Measurement of Current through circuit: _____ mA

4. Voltages and Currents in Parallel Circuit

Resistor	Measured Resistance (Ω)	Voltage Across Resistor (V)	Predicted Current Through Branch (mA)	Directly Measured Current
R1				
R2				
R3				

^For each resistor disconnect one end and insert the ammeter: Fig10

Questions and Analysis

- 1) Explain why you expect the current to be the same for all elements connected in series
- 2) Why is the current in elements connected in parallel not the same for all elements? What parameter is identical for all elements connected in parallel
- 3) Assume that in your home the washing machine and the TV are on at the same time. Do you expect them to be connected in parallel or in series?
- 4) What do you expect to happen if you attempted to read the voltage across a car battery with the multimeter accidentally in ammeter mode?
- 5) What will be the effect of attempting to measure current with the multimeter left accidentally in voltmeter mode?

Name of Student: _____

Date Performed: _____

Instructor's Initial: _____